



2024



# AIR FORCE JUNIOR ROTC



## NORTH TEXAS CADET LEADERSHIP COURSE & SENIOR LEADERSHIP COURSE GUIDE

CADET NAME: \_\_\_\_\_

UNIT NUMBER: TX-\_\_\_\_\_

FLIGHT: \_\_\_\_\_

ROOM NUMBER: \_\_\_\_\_

## TABLE OF CONTENTS

Chapter 1 – Introduction and Course Overview	3
Chapter 2 – Customs and Courtesies	5
Chapter 3 - CSLC and CLC Positions, Responsibilities, and Job Descriptions	8
Chapter 4 – Meals and Dining Etiquette	11
Chapter 5 – Room Arrangement and Inspection Information	13
Chapter 6 – Safety, Hygiene and Other Cadet Concerns	23
Chapter 7 – Recognition / Awards	27
Appendix 1 – National/Air Force Chain of Command	28
Appendix 2 – Cadet Leadership Course (CLC) Chain of Command	29
Appendix 3 – Air Force Rank Structure	31
Appendix 4 – Air Force Junior ROTC Rank Structure	32
Appendix 5 – Air Force and Army ROTC Rank Structure	33
Appendix 6 – Phonetic Alphabet	34
Appendix 7 – Air Force Song	35
Appendix 8 – United States Air Force Core Values	36
Appendix 9 – Cadet Uniform Requirements	37
Appendix 10 – CLC/CSLC Cadet Uniform Inspection Checklist	39
Appendix 11 – CLC/CSLC Cadet Room Inspection Checklist	41
Appendix 12 – Formal Drill Competition	42
Appendix 13 – 30-Step Drill Sequence Explained	47

## CHAPTER 1 – INTRODUCTION AND COURSE OVERVIEW

**1. Welcome:** Welcome to the Cadet Leadership Course (CLC) and Cadet Senior Leadership Course (CSLC)! CLC/CSLC will challenge you and provide you an opportunity to learn more about leadership, followership, teamwork and citizenship. The best leaders are also good team members, wingmen, followers and role models. The best leaders serve the people they lead and propel them to achieve more than they thought they could.

*"The greatest leader is not necessarily the one who does the greatest things. He is the one that gets the people to do the greatest things."*

Ronald Reagan (40<sup>th</sup> President of the United States – 1981-1989)

**2. Why are you here?** Being a leader and/or follower is a tough, frustrating and rewarding experience. It takes hard work and selfless dedication to help others be successful. You are here to learn about and experience leadership and followership. While at CLC/CSLC you will be challenged through drill, academics, team sports and team building activities. Take what you learn and make your JROTC program the best!

**3. Why were you chosen?** You were selected for this opportunity based on your performance, skill and potential. The purpose of CLC is to make you a better cadet leader, follower and wingman. Challenge yourself to be better than you are. Learn from the instructors, Cadet Training Officers (CTOs) and from each other. Then apply what you learn to make yourself a better leader, follower and wingman. The success of your corps depends on how well you lead, follow, your ability to be a good wingman and your ability to do your JOB.

**4. The Cadet Guide.** This guide contains information on rules regarding policies, procedures, conduct and performance of cadets. You are expected to read the Cadet Guide and have it with you **at all times** except as otherwise directed by a CTO or instructor. Your knowledge, understanding and compliance with this guide along with your positive and “can-do” attitude will contribute to your success at CLC/CSLC. Additionally, you are required to comply with all special notices posted in the dormitory and information from the CTOs or instructors. These policies and procedures have been developed to help you be successful at CLC/CSLC, to increase your level of self-discipline and keep you safe.

**5. Bottom Line Up Front (BLUF).** The secret to doing well in CLC/CSLC is to apply all those great things about being a cadet leader, follower and wingman your instructors have taught you. You already have the basic skills and knowledge. All you have to do is:

- a. Take your performance to a higher level by building on what you know.
- b. Discover what you don't know and make it something you know.
- c. Have a goal to make yourself a better version of yourself.
- d. Take the opportunity to lead and challenge yourself – DO NOT QUIT! Get involved, follow the rules, cooperate together to learn something new.
- e. Challenge yourself to be open to others ideas and different perspectives. Take a risk and try something new. You may learn better ways to accomplish tasks by being perceptive and open to new ideas.

**6. AFJROTC Cadet Creed:** The Cadet Creed is essential to the operation of CLC and the foundation for your success as an AFJROTC cadet. Any cadet found violating the tenants of the Cadet Creed may be sent home at their own expense.

I am an Air Force Junior ROTC Cadet.

I am connected and faithful to every Corps of Cadets who serve their community and nation with patriotism.

I earn respect when I uphold the Core Values of Integrity First, Service before Self and Excellence in All We Do.

I will always conduct myself to bring credit to my family, school, Corps of Cadets, community and to myself.

My character defines me. I will not lie, cheat or steal. I am accountable for my actions and deeds.

I will hold others accountable for their actions as well.

I will honor those I serve with, those who have gone before me and those who will come after me.

I am a Patriot, a Leader and a Wingman devoted to those I follow, serve and lead.  
I am an Air Force Junior ROTC Cadet.

**7. Hazing, Harassment, Threatening, etc.** Any type of hazing, harassment, threats, bullying, sexual advances or misconduct, of a verbal, electronically transmitted and/or physical nature, any combination thereof toward a fellow cadet, CTO, instructor or any other person(s) associated with CLC/CSLC will not be tolerated. This is a ZERO TOLERANCE rule...any cadet found in violation of this rule will be immediately turned over to their instructor and sent home at their own expense! If you are the victim of such behavior OR aware of such behavior, you must contact your instructor, the CLC Commandant and/or the CLC Superintendent **immediately**.

**8. Uniform of the Day (UOD):** There are two possible UOD combinations while at CLC/CSLC. You will dress in the UOD according to the schedule each day.

- a. Physical Training Gear (PTG) – Air Force or unit PT shirt, PT shorts, athletic socks, and athletic shoes.
- b. Class-B Service Uniform (Class-B) – AFJROTC short-sleeve blue uniform without tie.
- c. Each cadet will always carry their CLC/CSLC issued cinch bag and a full water bottle with them whenever they travel around campus. Cadets will wear the cinch bag in either uniform across their back by using the cinch straps as backpack straps. The cinch bag will be worn across both shoulders with the screen print facing outward. Cadets may take off their cinch bag once they arrive at a location for an event or at CTO or instructor direction.

## CHAPTER 2 – CUSTOMS AND COURTESIES

**1. Greetings and Salutes:** Cadets are required to exchange salutes when in the Class-B Service Uniform with all CTOs who have black and silver rank insignia, as well as military officers of any branch of service. At no time will a cadet turn their upper body to salute someone behind them nor will they salute someone they approached from the rear. If in a classroom and a SASI, active-duty officer, or a CTO enters, call the room to attention. Once classroom instruction begins, only call the room to attention if an O-6 (Colonel) or above enters the room.

a. Cadets will render proper greetings of the day to the CTOs, active duty, and JROTC personnel at all times. Unless cadets are in the classroom for instruction or in formation, all cadets will use the proper greeting of the day. When in formation, the Flt/CC will render a salute if applicable and simultaneously greet on behalf of the formation. You should make every attempt to learn and memorize the names of all CTOs as soon as possible; “CTO (name)” will be substituted for the “Sir/Ma’am” portion of all greetings from this point forward. If you are greeting a group of men, a group of women, or a combination thereof, you will use “gentlemen,” “ladies,” or “ladies and gentlemen” as appropriate.

b. The greeting changes from “good morning” to “good afternoon” or from “good afternoon” to “good evening”, the moment you **LEAVE** the dining facility.

1) Before Lunch: “Good Morning, Sir/Ma’am”

2) After Lunch: “Good Afternoon, Sir/Ma’am”

3) After Dinner: “Good Evening, Sir/Ma’am”

**2. Saluting Courtesies to the U.S. Flag:** When outdoors and in uniform, as the U.S. flag passes by, stand at attention, salute six paces before the flag passes you and hold your salute until the flag is six paces past you. Females do not have to remove their hats. Flags on stationary flagstaffs are only saluted during Reveille, Retreat, or special ceremonies.

**3. Exceptions to Saluting:** There are several exceptions to saluting. The following situations do not address every possible situation. Exercise good judgment when confronted with all situations.

- If your arms are full, you don’t have to salute; simply extend a verbal greeting. Always try to keep things in your left hand if possible so you can salute.

- If an officer’s hands are full, but yours are not, extend a verbal greeting and salute. Once the officer acknowledges your salute or passes you, drop your salute.

- Do not salute indoors, except during formal reporting, and during some ceremonies.

- Salutes are not required if either person is in civilian clothing. You may salute if you recognize the officer.

**4. Reporting Statements:** Cadets will use reporting statements at ALL times. In order to raise the hand, the hand must be in a fist (similar to the position of Attention) with the thumb to the back, extended vertically with the bicep touching the right ear. \*This will be demonstrated at CLC. “Sir/Ma’am, Cadet \_\_\_\_\_ reports (as ordered, to ask a question, etc.)”

**5. Five Camp Responses:** Anytime a cadet initiates communication with a CTO or instructor, the following responses must be used in the appropriate manner.

- a. “Yes, Sir/Ma’am”
- b. “No, Sir/Ma’am”
- c. “Sir/Ma’am, may I ask a question?”
- d. “Sir/Ma’am, may I make a statement?”
- e. “Sir/Ma’am, I do not know but will find out.”

**Note:** After the first day of CLC/CSLC, cadets will be expected to address each cadre member by rank and last name (e.g., Lt Col Addison, CMSgt Davis, 2d Lt Chambers, CTO Taylor, etc.).

**6. Basic Etiquette:** The following procedures will be followed the entire week of attendance at CLC/CSLC unless otherwise directed:

- a. Moving on the right side. When moving other than in formation, cadets will march on the right side of any hallway, stairwell or path and square all corners.
- b. Shirts and shoelaces tucked in. Shirts and shoelaces must be tucked in at all times, whether in uniform or civilian clothing.
- c. How to ask a question. Before asking a question or making a statement, a cadet will stand at attention and raise their right arm so the upper arm is touching their right ear. The hand should be closed as in a fist. Once recognized, the cadet will return to attention and use the appropriate camp response.
- e. When a CTO or instructor enters a room, stand at attention. If more than one person is present, the first person to see the CTO/instructor will call the group to attention. However, if an officer of equal or higher rank is already in the room, do not call the room to attention. Call the room to attention again as the CTO or instructor (whomever is higher rank departs first).

## **7. Movement in the Dormitory**

- a. While moving throughout the dormitory floor, cadets will march at quick time and follow their floor’s flight path. The flight path is an established path around each floor’s rooms and indicated with tape on the floor.
- b. Grounding: When in the dormitory hallway and directly approached by a CTO or instructor, cadets will “ground” themselves against the nearest wall, at the position of attention, positioning the five points as necessary and against the wall (Figure 1). Once the cadet is “grounded,” they will respond with the appropriate verbal greeting. If a cadet approaches a stationary CTO, the cadet will greet and continue to move without stopping.

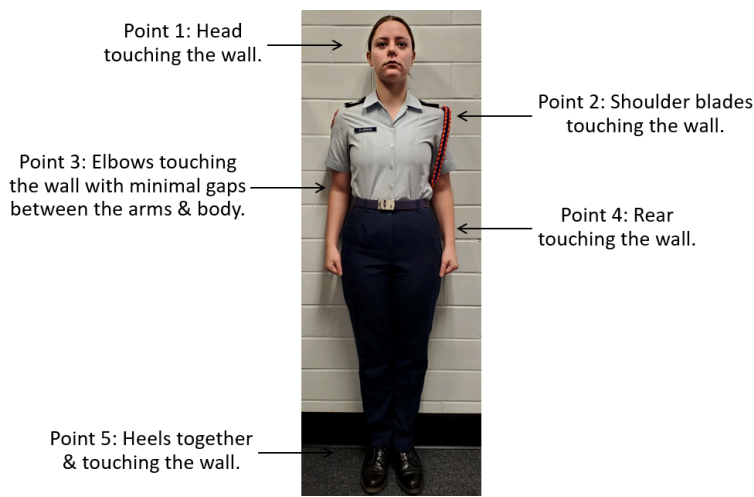

Figure 1: Grounding

c. Center Line: When called to the “Center Line” by a CTO, cadets will ground themselves outside the doorway of their assigned room. If a cadet is away from his or her room, at “Center Line,” they will ground themselves against the wall closest to their current location. Cadets will not use greetings while at “Center Line.” When a cadet leaves his or her assigned room they must be in uniform (blues or PTs). This includes the morning “Center Line.” PTs with shower shoes are acceptable when in your room and in the evenings during CTO time prior to lights out.

d. Elevators and Stairwells: Cadets on floors 4 or below will ALWAYS use the stairwells – the elevators in Guinn Hall are off-limits for cadets on these floors unless specifically authorized by a CTO or instructor. Cadets on floors 5 or above will primarily use the stairwells to leave Guinn Hall. Cadets on floors 5 or above may use either the elevators or stairs to reach their assigned floors when entering Guinn Hall. Cadets will move at the position of attention. Cadets must use handrails while on the stairs. At no time are cadets to run, jog, stop or stand on the stairs. Cadets will not “ground” themselves in the stairwells. When passing a CTO or instructor, cadets will use the appropriate greeting and move on.

e. No Lying Down: Unless directed by a CTO or instructor, cadets will not lie down on a bed or floor while in their assigned room prior to lights out. Cadets may sit in the chairs in their room while studying, preparing their uniforms, assisting their wingmen, etc.

f. Gender Separation: Male and female cadets will be roomed in Guinn Hall with their flight’s CTO. Other than flight time with a CTO, male cadets are not authorized in the female cadets’ portions of the floor(s) nor are female cadets allowed in the male cadets’ portion of the floor(s). Each floor of Guinn Hall will be clearly marked with visible barriers between the male and female sections of the floor. If a CTO or instructor of the opposite gender needs to enter an area of the floor or room housing the opposite sex outside of flight time, the statement “Male/Female in the area” must be stated in a loud voice upon entering the area. The doors to each room must always be open. The ONLY exception to the doors always being opened is when changing clothes and during lights out. **A single male cadet will never be alone with a single female cadet in any room during CLC/CSLC. If this instance occurs, both cadets will be dismissed immediately from CLC/CSLC by their respective instructors or the Commandant.**

## CHAPTER 3 – CSLC and CLC POSITIONS, RESPONSIBILITIES, and JOB DESCRIPTIONS

1. **Overview:** CSLC cadets will be assigned to senior positions of responsibility throughout the various levels of the North Texas CLC/CSLC Cadet Group. All cadet officer positions below will be filled by CSLC cadets while all cadet enlisted positions will be filled by CLC cadets. CSLC cadets not assigned to positions will wear c/Second Lieutenant rank and CLC cadets not assigned to positions will wear c/Staff Sergeant rank.
2. **Group Commander (GP/CC):** The GP/CC is the overall leader of CLC/CSLC and highest ranking CSLC cadet. The GP/CC is responsible for ensuring the smooth and efficient execution of the day's schedule of activities through the Group Staff. Authorized rank – c/Colonel.
3. **Deputy Group Commander (GP/CD):** The GP/CD is a member of the Group Staff and responsible for executing tasks assigned by the GP/CC. The GP/CD is authorized to make decisions in the event of the GP/CC's absence. Authorized rank – c/Lieutenant Colonel.
4. **Group Support Officer (GP/SO):** The GP/SO is a member of the Group Staff and responsible for DFAC procedures to include: preparing DFAC for cadet meals, repositioning glasses of water/hydration for cadets for each meal, proper cadet flow through the DFAC, and any other tasks assigned by the GP/CC. Authorized rank – c/Major.
5. **Group Standardization Officer (GP/STANDO):** The GP/STANDO is a member of the Group Staff and responsible for the overall standardization of CLC/CSLC, cadet room and uniform inspections, and any other tasks assigned by the GP/CC. Authorized rank – c/Major.
6. **Group Logistics Officer (GP/LG):** The GP/LG is a member of the Group Staff and responsible for all cadet CLC/CSLC supplies and any other tasks assigned by the GP/CC. Authorized rank – c/Major.
7. **Group Drill and Ceremonies Officer (GP/D&C):** The GP/D&C is a member of the Group Staff and responsible for the overall drill and ceremonies at CLC/CSLC. These include reveille, retreat, 30-basic drill evaluation, the graduation pass-in-review, and any other tasks assigned by the GP/CC. Authorized rank – c/Major.
8. **Group Command Chief (GP/CCC):** The GP/CCC is a member of the Group Staff, reports directly to the GP/CC, and is the highest ranking CLC cadet. The GP/CCC fulfills direct access to the Group Staff for CLC cadets and any other tasks assigned by the GP/CC. Authorized rank – c/Chief Master Sergeant.
9. **Squadron Commander (SQ/CC):** The SQ/CC is a member of the Group Staff. There will be at least two SQ/CCs (SQ 1/CC & SQ 2/CC) responsible for at least three flights each. The SQ/CC is responsible for ensuring the smooth and efficient execution of the day's schedule of activities for their respective squadron and any other tasks assigned by the GP/CC. Authorized rank – c/Lieutenant Colonel.
10. **Squadron Deputy Commander (SQ/CD):** The SQ/CD is responsible for executing tasks assigned by the SQ/CC. The SQ/CD is authorized to make decisions in the event of the SQ/CC's absence. Authorized rank – c/Major.



- 11. Squadron Support Officer (SQ/SO):** The SQ/SO is a member of the Squadron Staff and responsible for DFAC procedures to include: preparing DFAC for cadet meals, prepositioning glasses of water/hydration for cadets for each meal, proper cadet flow through the DFAC, and any other tasks assigned by the SQ/CC. Authorized rank – c/Captain.
- 12. Squadron Standardization Officer (SQ/STANDO):** The SQ/STANDO is a member of the Squadron Staff and responsible for the overall standardization of their Squadron’s cadet room and uniform inspections, and any other tasks assigned by the SQ/CC. Authorized rank – c/Captain.
- 13. Squadron Logistics Officer (SQ/LG):** The SQ/LG is a member of the Squadron Staff and responsible for their Squadron’s supplies and any other tasks assigned by the SQ/CC. Authorized rank – c/Captain.
- 14. Squadron Drill & Ceremonies Officer (SQ/D&C):** The SQ/D&C is a member of the Squadron Staff and responsible for the overall drill and ceremonies of their Squadrons. These include assigning cadets to perform reveille and retreat, supporting the 30-basic drill evaluation, graduation pass-in-review, and other tasks assigned by the SQ/CC. Authorized rank – c/Captain.
- 15. Squadron Superintendent (SQ/CCS):** The SQ/CCS is a member of the Squadron Staff, reports directly to the SQ/CC, and is the highest ranking CLC cadet in the Squadron. The SQ/CCS fulfills direct access to the Squadron Staff for CLC cadets and any other tasks assigned by the SQ/CC. Authorized rank – c/Senior Master Sergeant.
- 16. Flight Commander (FLT/CC):** The FLT/CC is a member of the Squadron Staff. The FLT/CC is responsible for ensuring the smooth and efficient execution of the day’s schedule of activities for their flight any other tasks assigned by the SQ/CC. Authorized rank – c/Captain.
- 17. Flight Support Officer (FLT/SO):** The FLT/SO is a member of the Flight Staff and responsible for DFAC procedures to include: preparing DFAC for cadet meals, prepositioning glasses of water/hydration for cadets for each meal, proper cadet flow through the DFAC, and any other tasks assigned by the FLT/CC. Authorized rank – c/First Lieutenant.
- 18. Flight Standardization Officer (FLT/STANDO):** The FLT/STANDO is a member of the Flight Staff and responsible for the overall standardization of their Flight’s cadet room and uniform inspections, and any other tasks assigned by the FLT/CC. Authorized rank – c/First Lieutenant.
- 19. Flight Logistics Officer (FLT/LG):** The FLT/LG is a member of the Flight Staff and responsible for their Flight’s supplies and any other tasks assigned by the FLT/CC. Authorized rank – c/First Lieutenant.
- 20. Flight Drill and Ceremonies Officer (FLT/D&C):** The FLT/D&C is a member of the Flight Staff and responsible for the overall drill and ceremonies of their Flight. These include assigning cadets to perform reveille and retreat, supporting the 30-basic drill evaluation, graduation pass-in-review, and other tasks assigned by the FLT/CC. Authorized rank – c/First Lieutenant.

**21. Flight Sergeant (FLT/SGT):** The FLT/SGT is the highest ranking CLC cadet in the flight, responsible for leading the flight in the FLT/CC's absence, and executing tasks assigned by the FLT/CC. The FLT/SGT is authorized to make decisions in the event of the FLT/CC's absence. Authorized rank – c/Master Sergeant.

# CLC/CSLC Organizational Chart

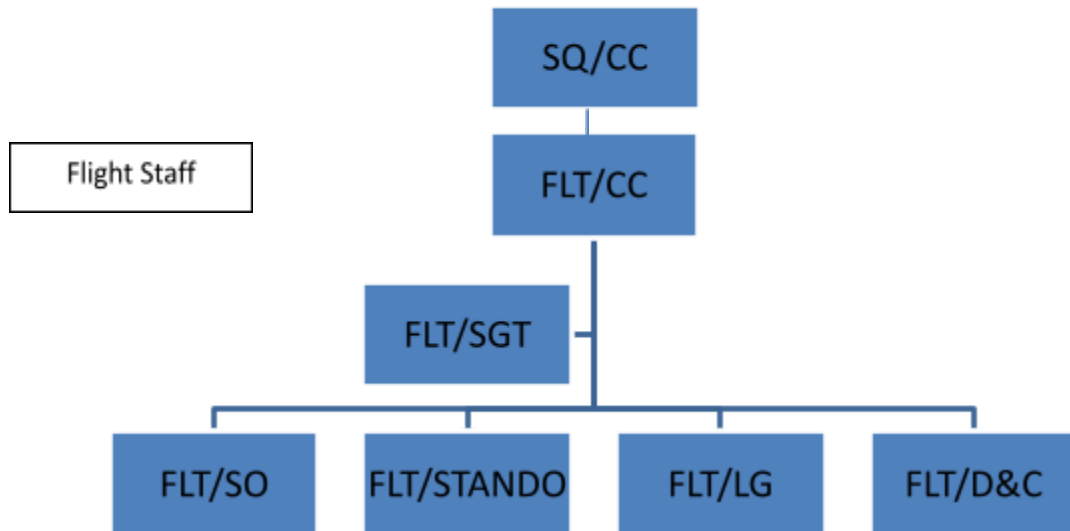
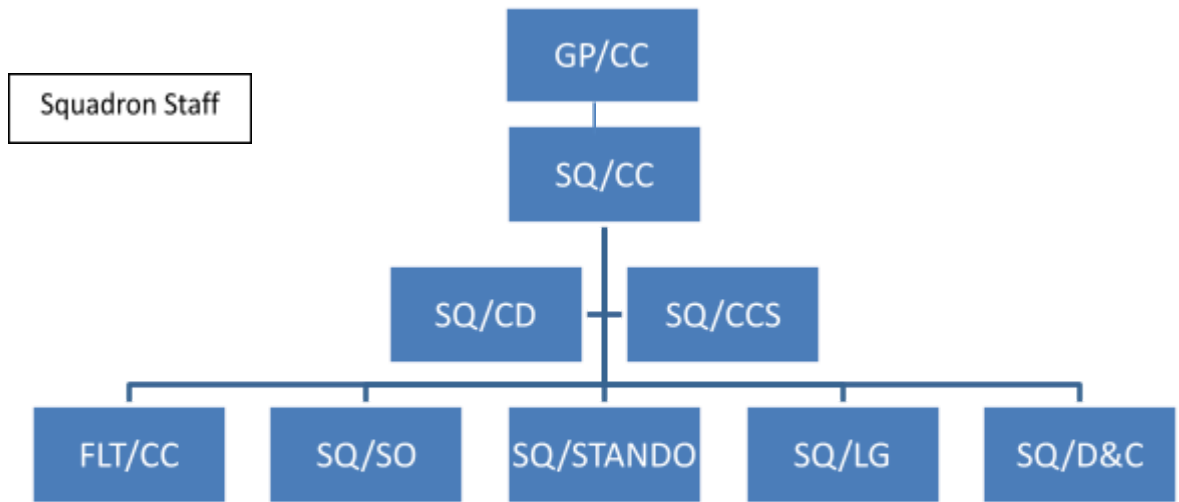
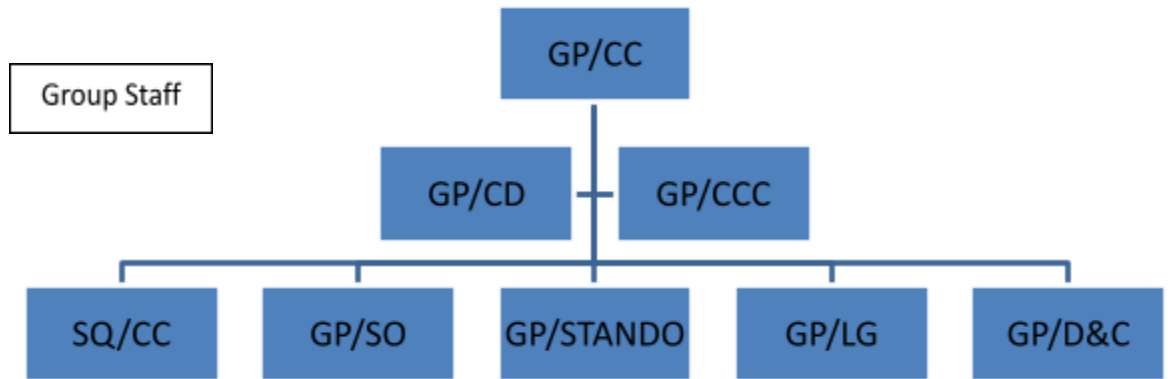

## CHAPTER 4 - MEALS AND DINING ETIQUETTE

**1. Dining Facility (DFAC) Entry:** Flight commanders will position their flights for entry, so they are not blocking the main entry door of the DFAC. Flights will enter via “column of files” formation in a single file with the flight’s guidon bearer leading the flight inside. The flight commander will be the last person of their flight to enter the DFAC. Guidon bearers will post their guidons immediately outside the DFAC for easy retrieval at exit. DO NOT prop or hold open the DFAC door to enter and do not block civilians’ entry or exit from the DFAC. Remember you are a guest at the DFAC and there are civilians observing everything you do – do not cause disrespect or undue attention to AFJROTC or your unit.

**2. Waiting in Line:** While waiting in line to enter or once inside the DFAC, cadets will stand at parade rest. When there is room to move forward, cadets will come to attention, move forward and reassume parade rest. Cadets are not required to greet CTOs or instructors while in line. Unless otherwise directed, talking amongst cadets is not permitted while in the DFAC. Cadets may speak to DFAC personnel to order and ask or answer specific questions. Cadets may use the restroom prior to getting their meals but will re-enter the line to get their food just inside the doorway at the DFAC entry – cadets will not cut in line with their flight.

### **3. Meals**

a. Drinks: Cadets are required to drink two glasses of fluids at each meal—one must be water and the other may be another glass of water, Powerade, milk (white or chocolate) or juice. **At no time will cadets drink soda, coffee, tea or other caffeinated beverages.**

b. Food: Cadets are not permitted to have dessert at any meal. Dessert is classified as candy, cake, cookies, pie, Jello, ice cream, etc. CTOs will clarify further if there are any specific examples at meals.

c. Waiting to be Seated: As cadets finish receiving their food, they will march to the first available table via the most direct route. Once they reach their seat, they will place their tray on the table in front of them and remain standing at the position of attention until all cadets sitting at the table are present or a CTO gives them permission to be seated. Once cadets are seated, they will position themselves as displayed in Figure 2.

Head & back straight up & down; perpendicular to the ground.

Both hands will remain under the table when not eating. The secondary hand will remain under the table at all times.



Cadets will sit on the last 6 inches of the chair.

Upper abdomen against the table.

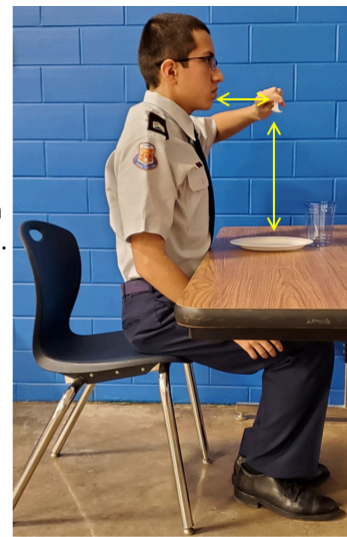

90° "Squared Meals"

Figure 2: Meal Etiquette

d. Consuming your Meal: When cadets begin to eat, they will remain at the position of "in-seats attention." Plates, cups and silverware will be arranged as displayed in Figure 3. Cadets are expected to have a "tight meal" posture during all meals in the dining facility. This means cadets will sit at the position of attention and not talk or look around. Cadets will eat in silence; however, they may ask a tablemate in a hushed voice to pass an item at the table if it is out of reach.

Cups with water and Powerade centered and grounded against the plate. Note for breakfast, cadets may substitute a glass of milk or juice for the Powerade. Cadets may always have a second glass of water.

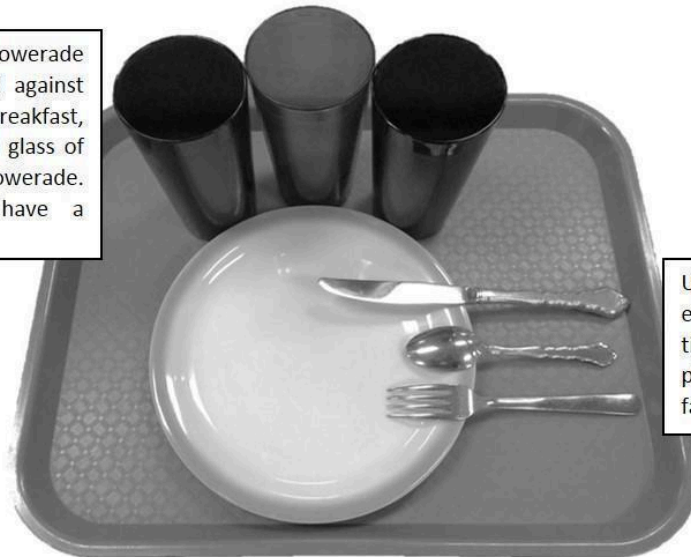

Utensils will be positioned exactly in this order, with the tip of each utensil on top of the plate. The spoon and fork will face downward.

Figure 3: Tray Arrangement

**4. After the Meal:** Once all cadets at the table are finished, they will take their tray to the tray return section to be washed and then exit the DFAC. If a cadet finishes their meal before the rest of the table, they will open and study their "Cadet Guide" until the remaining cadets finish their meal. Cadets should use this time after finishing their meals and before exiting the DFAC to use the restroom.

**5. Exiting the DFAC:** As cadets leave the DFAC, they will begin to form their flights in the Southwest corner of the parking area immediately in front of the DFAC using any open handicapped parking spaces. Remember, civilians are also eating in the DFAC and to not disturb them as your flight exits the building. Flight commanders and guidon bearers should be mindful to stay clear of any traffic in this small space.

## CHAPTER 5 - ROOM ARRANGEMENT AND INSPECTION INFORMATION

**1. General Room Arrangement and Inspection Information:** Each room that has a single item such as a closet or desk will be divided into two sides from the viewer's perspective. The alphabetically first by last name cadet will use the left side of the item and the other cadet will use the right side. Follow the same standard when using other items that are duplicated in the room. For example, when facing the foot of the beds, the alphabetically first by last name cadet will be on the left and the other cadet will be on the right. If the duplicated items are on opposite sides of the room, apply left and right standards from the perspective of just entering the room. **You MUST put your room inspection sheet (will be in your room upon arrival or given to you by your Flt/CC) centered on your pillow prior to leaving the room for Breakfast each day. Failure to do so will result in a 20-point deduction from your room inspection grade.**

Additional room standardization information will be passed along from your flight's standardization officer, based on cadet Group Commander/Staff guidance once CLC/CSLC begins.

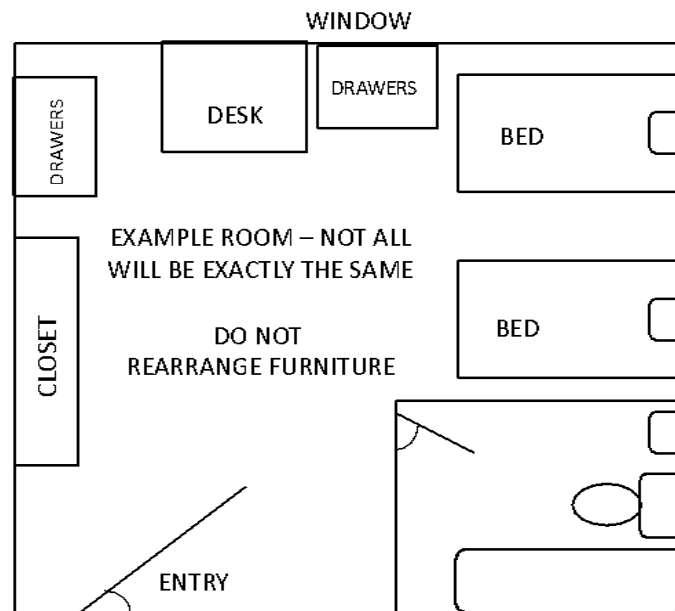

Figure 4: Example Room Arrangement (Guinn Hall)

**2. Air Vent:** The air vent will remain open at all times.

**3. Window and Blinds:** The window and blinds will remain closed at all times. Window blinds will be closed so they face downward. The windowsill will be free of dust and dirt.

**4. Dresser Drawers:** Dressers will be clean on top, free from dirt and dust.

- a. Guinn Hall: Each cadet will use the dresser drawer on their respective side of the room. Each drawer will have an opening of 2" as shown in Figure 5.

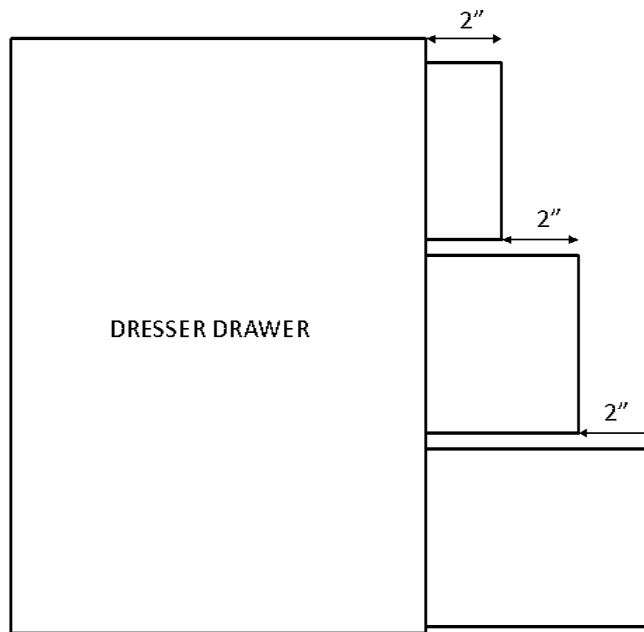

Figure 5: 2" Drawer Opening (Side View)

b. The layout for drawer organization will be demonstrated by your flight CTO on the first day. It is imperative that you pay close attention to the demonstration.

- (1) The top drawer is the clothing drawer. All undergarments, socks, T-shirts, and shorts will be in this drawer. See Figure 6 below for a guide. If applicable, bras will be folded cup-into-cup with the straps tucked under. Bras will be grounded against socks and toward the back of the drawer.

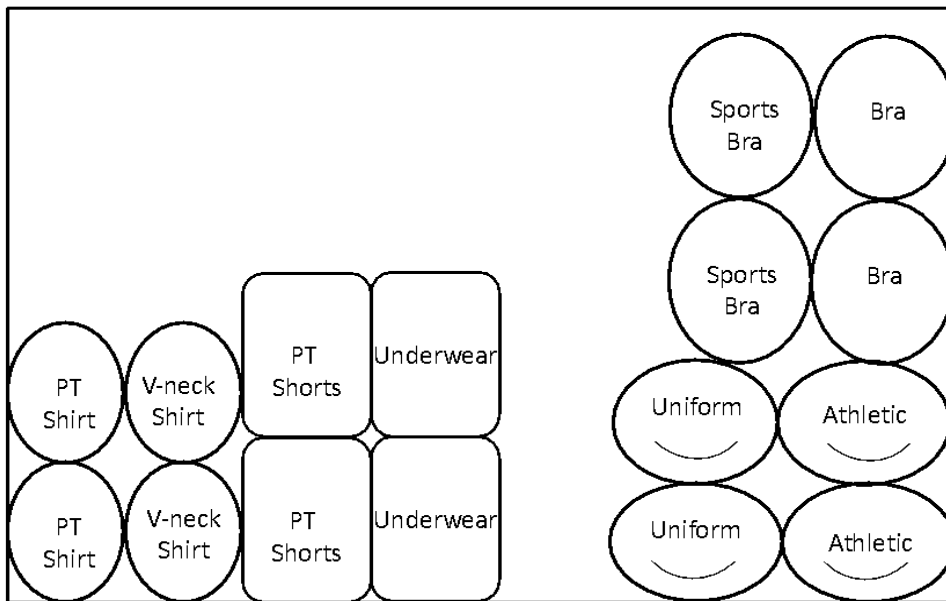

Figure 6: Top (First) Dresser Drawer



(2) The middle drawer is the hygiene drawer. Items needed to maintain personal hygiene will be in this drawer: toothpaste, deodorant, soap, shampoo, shaving kit, washcloths, etc. The toothpaste will be grounded against the bottom and left side of the drawer. The deodorant will be sealed and will be grounded against the bottom of the drawer and the right side of the toothpaste. The shampoo will be grounded against the bottom and right side of the drawer. The soap (inside the container) will be grounded against the bottom of the drawer and the left side of the shampoo. Do not place wet soap in the drawers. If there are additional hygiene products, ground with the bottoms to the front and tallest to the outside working to shortest toward the middle of the drawer.



Figure 7: Second Dresser Drawer Layout

(3) The bottom drawer is the personal items drawer. It must be kept organized and clean. This drawer will have any other items that do not classify into the other drawers (e.g., study materials, towels (dry), etc.). Follow the same procedure by grounding items to the front, then to each other.

**5. Microwave and Refrigerator:** Each room has a microwave and refrigerator; however, these items will not be used by CLC/CSLC cadets during their stay. Cadets should not touch or operate either appliance during CLC/CSLC.

## 6. T-Shirts:

- Rolled with the open edge down, single fold to the left. Place shirts in one row from the front of the drawer to the back, stacking if necessary.
- Ground PT T-shirts to the front left corner of the drawer, as you are looking into the drawer.
- Ground white T-shirts (optional for females) to the front of the drawer and to the right of the PT T-shirts.

## 7. Instructions for Rolling T-shirts (White/PT)

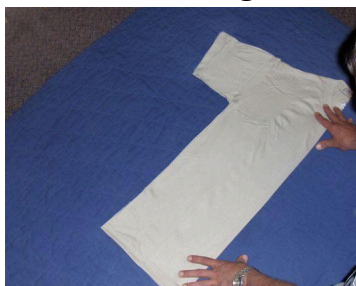

a. Lay the T-shirt flat. Ensure edges are even. Fold the shirt in half lengthwise, down the middle of the shirt.



b. Fold the sleeves in so the shirt forms a rectangle.

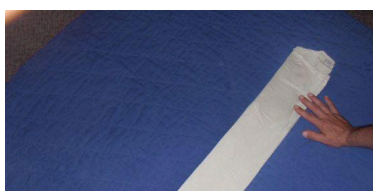

c. Fold the T-shirt in half lengthwise again.

d. Tightly roll the T-shirt starting from the waist toward the collar.

When properly folded and rolled, single folds will be on the left side with edges as even as possible.

### 8. Instructions for Rolling Underwear/ PT Shorts

Rolling will be the same for all types of underwear and shorts for both genders.



a. Lay flat with the front side facing down, waistband away from you.



b. Fold in half from crotch to waistband. Crotch should be even with the top of the waistband. Fold excess over to make top even.



c. Square the garment by folding the sides in equal thirds neatly towards the center. Starting with the left side, fold one third of the garment from left to right. Then fold the right side over the left. Ensure you keep edges even as you fold. Excess material may be tucked in to square the edges.



d. Turn the garment over (front facing up). When folded properly, there will be a single fold on the left. The open end will be to the right. Edges will be as even as possible.

### **9. Bras/Sports Bras:**

Stack with the cups facing up. If you are displaying sports bras, they will be stacked underneath the regular bras.

### **10. Instructions for Folding Bras**



a. Place one cup inside the other cup. Make sure the single fold is on the left.

b. Tuck the straps and back of the bra completely inside the cups.

### **11. Instructions for Folding Sports Bras**



a. Lay the bra flat with the front down and the straps away from you.



b. Fold the straps down until flush with the bottom edge of the bra.



c. Fold the bra from left to right in half, keeping all edges even. Single fold will face the left.

**12. Socks:** Roll socks in pairs. Applies to both uniform black and athletic socks, no matter length.



a. Lay a pair of socks flat (right side out), one on top of the other, and one sock offset by 2 inches. Starting with the toes, tightly roll towards the open end.



b. Turn the open end of the bottom sock inside-out back over the entire roll, securing it. The open end of the socks will be even with the roll and no excess sticking out past the roll. Place with smile facing up to the viewer.

### 13. Folding Instructions for Towels:

NOTE: Used (damp) towels and washcloths should be hung neatly over hangers in the closet to air dry.



a. Lay the towel flat as shown. Take the edge closest to you and fold the towel in half lengthwise, away from you, so it is approx. 12 inches wide.



b. Fold the towel in half lengthwise again, *toward* you this time, so it is approx. 6 inches wide.

Keep the edges as even as possible, and smooth out all wrinkles.

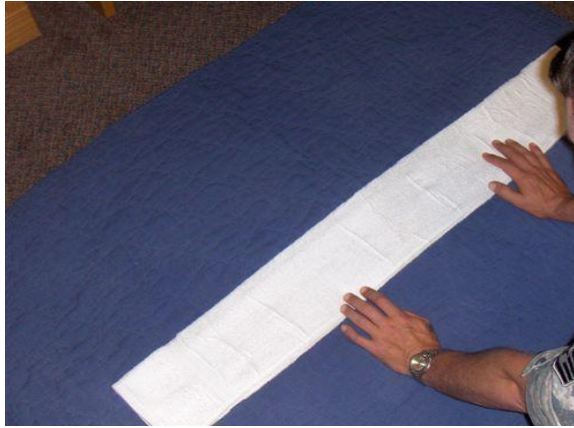

c. Starting from the end, tightly roll the towel from left to right. When complete, keep the edges as even as possible.

**14. Folding Instructions for Washcloths (Optional):** Lay the washcloth flat. Fold it in half from left to right, then in half from bottom to top away from you. Keep the edges as even as possible.

**15. Desk:** Desks will be clean on top, free from dirt and dust. Desk drawers (if present) will remain closed. Each cadet may use one desk drawer for extra items; however, CTOs routinely look in these drawers for contraband. Desks will be grounded to the wall and should not be moved from their position to rearrange the room.

**16. Chairs:** Chairs will be clean, free from dirt and dust. Chairs will be pushed into the desk and centered in the gap.

**17. Floor:** The floor will be clean and free from dirt and residue.

**18. Doors:** The entrance door will remain open as far as possible during all hours except when changing or at lights out.

**19. White Collar Bed:** Used during room inspections and the duration of CLC/CSLC.

a. Bottom (First) Sheet. Drape evenly over width of mattress. Ensure the bottom edge of sheet is flush with the foot end of mattress. Tuck excess under at the head end of mattress. Make hospital corners.

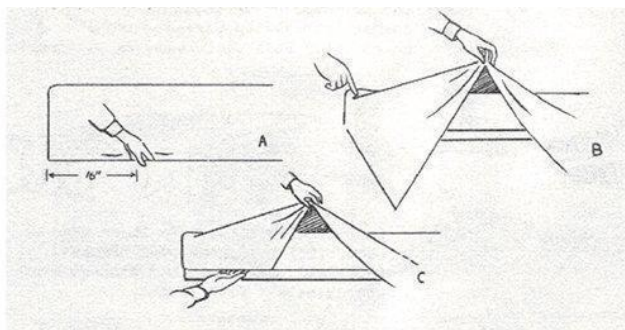

**NOTE:** Making hospital corners. (A) Grasp the side of sheet approximately 16 inches from the head end of mattress. (B) Lay the sheet on top of the mattress, creating a

45-degree angle. (C) Tuck excess material hanging down under mattress. (D) Next grasp 45-degree angle and without changing its shape, bring it down and (E) tuck under mattress. After sheet is completely tucked, smooth and tighten to the conformity of mattress.

b. Top Sheet. Drape evenly over width of mattress so that the top edge of the sheet is approximately 6 inches from the head end of the mattress. Tuck excess under the foot end of mattress. Do not make hospital corners on this sheet yet!

c. Drape the blanket evenly over the width of the mattress, with the end of blanket approximately six inches from the head end of mattress. Tuck the excess blanket under the foot end of mattress. Make hospital corners with both the sheet and the blanket, together, at the foot end. Tuck remainder of sheet/blanket under mattress. Smooth and tighten to conform to the mattress shape.

d. White Collar. Fold the top sheet and blanket over together to form a six-inch white collar and then fold again, so that the bottom of the six-inch collar is 24 inches from the head end of the mattress. Tuck remaining material hanging on the sides neatly under the mattress, including white collar. After the blanket and sheet are completely tucked, smooth and tighten to conform to the mattress shape.

e. Pillow and Pillowcase. Put pillow inside case. Center the length of the pillow on the width of the mattress, flush with the head end of the mattress. The open end of pillowcase faces away from the inspection side with the excess material neatly folded underneath.

f. Mattress. Center the mattress on the bed frame and ground to (push against) the head end of the bed.

**20. Sleeping Bag (optional):** Instead of twin-size sheets and a blanket, cadets may bring a sleeping bag. For room inspections, the sleeping bag will be folded neatly into a lower case “e” when viewed from side, centered and grounded to the foot of the bed (see Figure 8). A sleeping bag may also be used in place of a blanket.

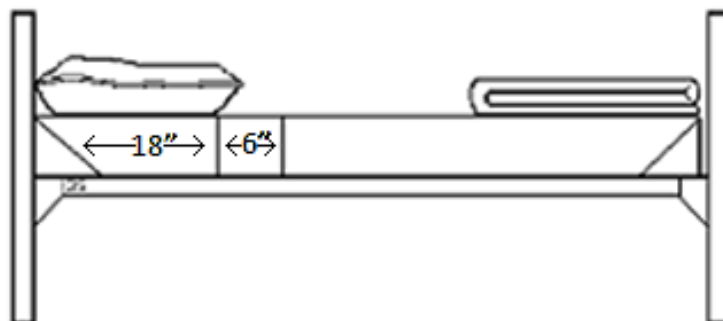

Figure 8: Bed Arrangement



**21. Closet and Uniforms (Figure 9):** When determining which side belongs to each cadet in Guinn Hall, remember the left side is the alphabetically first cadet in the room by last name. If there is only a single closet in the room, it will be shared by both cadets. If there happen to be two closets available in the room, apply the left/right standard from the perspective of the viewer at the doorway or as you face the closets, whichever is applicable.

a. Uniform Shirts: All uniform shirt buttons will be buttoned except for the top collar. Pocket buttons and epaulet buttons will also be buttoned. Blue uniform shirts will be inspection ready when hanging. Excess blue uniform shirts will be buttoned except for the top collar and free of accessories or “clean.” This means no nametags, ribbons and/or rank will be attached to the shirt while hanging. The unit patch will always face outward.

b. Uniform Pants: While hanging, pant legs will drape to the viewer’s left. The waistband will drape to the right, with the zipper facing outward. On the pants, all buttons will be buttoned, the zipper zipped and the top clasp connected. The pant legs and waistband will be flush and drape even with each other. The belt (if present) will be on the pants as if worn and will be buckled with just the silver tip exposed.

c. Shoes: Shoes will be grounded to the back wall and inside/outer edge of the closet under each cadet’s respective uniform items. The toes will face inward. Shoes will be arranged from left to right as shown in Figure 9 beginning with uniform low quarters, athletic shoes, and then shower shoes. Cadets are required to have either one pair of uniform low quarters or athletic shoes and one pair of shower shoes (or sandals) for inspection. Shoelaces will be tucked in (if present).

d. Towel and Washcloth: Each cadet will display one washcloth and one towel on separate hangers in their closet area. The washcloth will be hung centered on a hanger. The bottom edges of the washcloth will be flush and even. The towel will be folded in half and hung centered on a hanger. The folded side of the towel will face outwards. The bottom edges of the towel will be flush and even.

e. Cadets will hang their uniforms, towel and washcloth in the closet. If sharing the closet, the alphabetically first by last name cadet will hang their items starting from the left side of the closet and the other cadet will hang their items starting from the right side of the closet. Hangers will start 2” from the appropriate edge of the closet. Each hanger, after the first, will be spaced 2” from one another. Every cadet is required to have a minimum of one uniform shirt, one pair of uniform pants, one towel and one washcloth for inspection. Empty hangers will be removed from the closet bar. If a cadet wants to hang more than one shirt or one pair of pants, they may be hung in the closet (but must be inspection ready) or they can be kept in the bottom dresser drawer or their luggage.

e. Luggage/Garment Bags: Luggage or garment bags will be zipped and/or latched closed. They will be neatly placed on the top shelf of the closet and grounded against the appropriate edge and back wall of the closet.

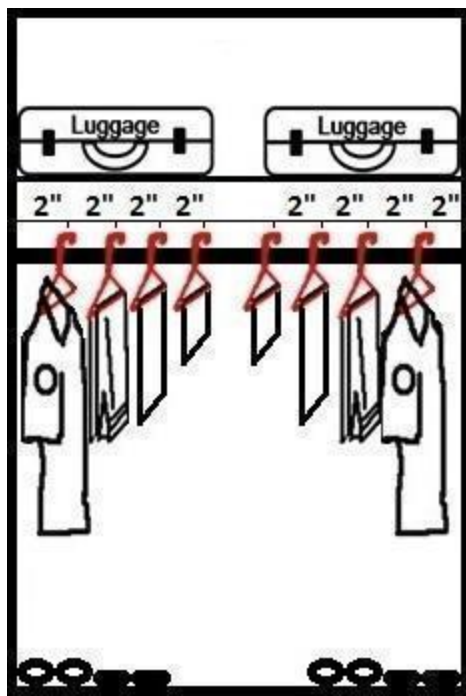

Figure 9: Closet Arrangement as Looking into the Closet (Some closets may have a center divider storage cubby – these will not be used for CLC/CSLC)

## 22. Bathroom Area:

- a. General: Bathroom areas are the responsibility of both cadets.
- b. Showers: Shower curtains will remain completely closed with the bottom of the curtain inside the tub. Any items in the shower will be neatly lined along the long-walled edge of the bathtub and grounded against the wall. Items will be placed in order from tallest to shortest with the tallest starting at the drain end of the tub. If a bathmat is used, it will be placed over the side of the tub and centered lengthwise between the tub ends.
- c. Mirrors: Bathroom mirrors will be clean and free from smudges, streaks, water residue and lint.
- d. Sinks: Sink drains will remain open and sinks will be free of standing water. The sink face will be clean, free from hair, dirt and soap residue. Faucets will be buffed clean, free from smudges, streaks and water residue. The only personal items visible in the bathroom will be cadet's toothbrushes in the holder.
- e. Bathroom Floors: Bathroom floors will be clean, free from dirt, hair or residue.
- f. Toilet: Toilets will be flushed after each use. Toilet lids will be open with the seats down. Any extra toilet paper rolls will be centered and grounded on the ledge above the toilet.

**23. Room Damage:** Immediately report any damage noted in the dorm room to your Flt/CC and or CTO.



## CHAPTER 6 – SAFETY, HYGIENE AND OTHER CADET CONCERNS

**1. Safety:** Safety is a top priority. Every good leader must understand nothing is more important than the safety of his or her subordinates. Inform your Flt/CC if you feel ill or in physical danger. Flt/CCs are the first line of communication for all immediate safety and health questions or issues. Any further medical/safety concerns and problems will be referred to your instructor for additional evaluation.

a. Hydration: All cadets must bring a water bottle or hydration pack for their own use during CLC/CSLC. It is mandatory cadets carry and use their water bottle **at all times when outside of Guinn Hall**. Hydration packs will not be worn while in the blue uniform. The Cadet Group Standardization Officer will determine the CLC/CSLC standard for hydration packs during blue uniform wear once CLC/CSLC begins. Dehydration is one of the largest health concerns at CLC/CSLC. It is important all cadets know the signs of dehydration and remain vigilant. The first indications of dehydration include headaches, lack of perspiration (sweat), cold and clammy skin and dizziness and nausea. If you or someone you know is experiencing any of these symptoms, notify a CTO or instructor immediately, no matter where or when it takes place.

b. Knee Locking: While standing in formation, cadets will not lock their knees. Locking your knees for any extended period can stop the circulation of blood and result in fainting. If you are in formation and feel dizzy, or see a fellow cadet beginning to collapse, you may break formation in order to prevent a potentially disastrous fall. Additionally, if someone close to you collapses, you are allowed to break formation to assist them.

c. Shoelaces Tucked In: Shoelaces should be tucked into the shoe at all times and in all uniforms during CLC/CSLC.

d. Emergency Procedures: In case of any emergency, it is vital all cadets remain calm and follow procedures and directions.

(1) Fire: If the fire alarm sounds remain calm and immediately proceed to the closest exit or stairwell. If in the dormitory, exit in a single-file line to the parking area along Chapel Dr, South of Guinn Hall (this is through the treed area path exiting the dorm). Immediately fall-in at your flight's designated location. After all flights fall-in, Flt/CCs will conduct roll call and accountability reporting any unaccounted-for cadets to CTOs or instructors. Flt/CCs must have an accurate flight roster at all times. If in any other area on campus, follow CTO or instructor instructions for formation and accountability areas. Flt/CCs will still report unaccounted for cadets.

(2) Tornado: In the case of a tornado, immediately leave your room, using the same procedures as outlined in the section entitled, "Movement in the Dormitory," and head toward the closest stairwell. Proceed to Guinn Hall lobby to enter the basement.

(3) Power Outage: In the case of a power outage, cadets will remain in their room. While there, cadets are instructed to turn on their flashlights and study their "Cadet Guide" until further instructions are given. Cadets must remain silent and calm.

**2. Hygiene:** Appearance and cleanliness are important to be a good leader as is effective time management. A subordinate cannot be expected to trust or respect a leader who is not capable of managing his or her own personal hygiene. CLC/CSLC will give cadets the opportunity to learn and demonstrate they can remain both clean and on-time. The following are daily requirements for all cadets. **Cadets are required to shower daily and to use soap.** Showers after morning PT may need to be quick to maintain the day's schedule, but all cadets will have plenty of time for evening showers prior to lights out if they manage their time well. For male cadets, facial hair must be shaved each day, including mustaches. **Deodorant must be used.** Cadets are required, but should not limit themselves, to brushing their teeth twice a day. Hair of any significant size on top of the head must also be combed every day. Females with long hair are advised to NOT put wet hair up in a bun for lights out to get a quick start in the morning. **Wet hair in a tight bun will begin to mold within a day and may cause additional health or hygiene issues if not allowed to air dry overnight.** Fingernails will be cleaned and clipped. If any cadet is missing one or more of the toiletry items needed to complete these tasks, they should inform their Flt/CC immediately so they can notify their respective instructor. Finally, to maintain basic health standards, it is **mandatory cadets wash their hands every time they use the restroom.**

**3. Medication:** Cadets must turn over all medication to their instructors during in-processing with instructions on dosage and dispensing. This includes all over the counter and prescription medication. It is recommended cadets arrive with their medications pre-loaded in a disposable container (plastic baggy or daily pill dispense pack) with the daily dosage in each container to make dispensing easiest. These medications will be labeled and kept by the instructor. Ideally, all medications will be distributed during breakfast or dinner to cadets so it may be consumed with food. Cadets with inhalers and/or Epi-pens are required to inform their Flt/CC, CTO and instructor of inhalers and/or Epi-pens in their possession but will not turn over the inhaler or Epi-pen. These cadets are always solely responsible for keeping their inhaler and/or Epi-pen on their person.

#### **4. Contraband:**

- a. Contraband is defined as any item/category not listed on the CLC/CSLC Cadet Packing List. All contraband not previously given to the cadet's instructor will be collected during in-processing and returned to the cadet's instructor after graduation.
- b. Concealing any item considered contraband will not be tolerated and cadets found to be in violation of this policy may be dismissed from CLC/CSLC and sent home at their own expense at the discretion of the Commandant and their instructor.
- c. Following is a list of common items cadets should consider contraband and will NOT be allowed at CLC/CSLC or in their rooms:
  - (1) Cell phones / electronic devices / car keys (turn in upon arrival if drove own vehicle)
  - (2) Perfume / cologne (body spray, lotion & aftershave are ok)
  - (3) Liquid shine
  - (4) Pumps (unless only issued footwear)
  - (5) Ropes / shoulder cords worn at home unit
  - (6) Wheel caps / sugar scoops / berets / any cover other than the flight cap
  - (7) Medals
  - (8) Air freshener
  - (9) Sunglasses (unless prescribed or medically necessary)

- (10) Stuffed animals
- (11) Jewelry of any kind is **STRONGLY** discouraged. **Note – cadets choosing to wear jewelry at CLC/CSLC must always comply with AFI 36-2903 and AFJROTC Supplements whether in uniform or PT gear.**
- (12) Food / snacks (your own or any removed from the DFAC)
- (13) Personal valuables
- (14) Medication (Epi-pen and inhalers only items allowed for cadets to maintain on their person)
- (15) Lighters

d. If there is a question whether an item is contraband at CLC/CSLC, ask your instructor before arrival or during in-processing.

e. Cell phones, car keys, and any daily medications will be collected at in-processing. Your unit instructor will distribute your daily medication based on instructions you provide during in-processing.

## 5. Academic and Classroom Etiquette

- a. The academic courses at CLC/CSLC can be demanding. To succeed, you must participate, take notes as necessary and pay attention.
- b. There is no talking during designated break sessions. Cadets will not sleep in class.
- c. Cadets are required to be respectful and courteous while in the classroom. When addressing an instructor in the classroom (e.g., to ask or answer a question); stand at attention, state your name and unit, then talk.

**6. Gender Separation:** Male and female cadets will be roomed in Guinn Hall with their flight's CTO. Other than flight time with a CTO, male cadets are not authorized in the female cadets' portions of the floor(s) nor are female cadets allowed in the male cadets' portion of the floor(s). Each floor of Guinn Hall will be clearly marked with visible barriers between the male and female sections of the floor. If a CTO or instructor of the opposite gender needs to enter an area of the floor or room housing the opposite sex outside of flight time, the statement "Male/Female in the area" must be stated in a loud voice upon entering the area. The doors to each room must always be open. The **ONLY** exception is when changing clothes and during lights out. **A single male cadet will never be alone with a single female cadet in any room during CLC/CSLC. If this instance occurs, both cadets will immediately be referred to their instructor and CLC/CSLC Commandant for dismissal consideration.**

## 7. Physical Training (PT) Procedures:

b. Overview: PT is an integral part of your cadet experience. Pushing yourself both physically and mentally will help make you better. PT will occur a couple times and may consist of such activities as warm-ups, calisthenics, running, competitive sports or flight competitions. On days PT is not performed, the AFJROTC physical fitness assessment or a short calisthenics session will take place.

b. At CLC/CSLC, your personal safety is of primary concern. If for ANY reason you feel ill, sick, injured or otherwise unable to participate or continue in any CLC/CSLC

physical activity, notify your Flt/CC, CTO or an instructor immediately. No one knows your body and limitations better than you.

c. Each cadet will take the AFJROTC physical fitness test once while at CLC/CSLC.

**8. Cadet CQ/Showers/Lights Out Procedures:** Cadet CQ is the time when cadets should begin to prepare for the next morning and begin to take their evening showers. Once Cadet CQ begins, cadets of the opposite sex are not allowed in the others' hallways. Cadets must sleep in their PT shirt and shorts overnight. This is to expedite reveille in the morning and in case of an overnight emergency. At lights out (NLT 2200 each night of CLC/CSLC), all cadets MUST be in their room, cadets will close their doors and go to bed – talking after lights out between cadet roommates is prohibited. Cadets WILL NOT open their doors or exit their rooms between lights out and reveille unless there is an emergency. Cadets will remain in their rooms overnight with lights out until reveille the next morning. Cadets may briefly use the toilet overnight (using their flashlight), if necessary. However, extended time in the bathroom preparing for the next day, showering after lights out, studying, reading, or any other reason beyond using the toilet is prohibited and an integrity violation that should be reported to either the cadet's Flt/CC or CTO as soon as practical.

## CHAPTER 6 – RECOGNITION & AWARDS

**1. Ribbons:** Cadets can earn various AFJROTC ribbons while at CLC/CSLC to include the following:

- a. Superior Performance Ribbon
- b. CLC Ribbon
- c. Special Teams Placement Ribbon
- d. Activities Ribbon

**2. Honor Graduate:** The two CLC and CSLC cadets with highest overall score (i.e., room inspections, uniform inspections, test scores, PFA score, and CTO score) will be recognized as the CLC or CSLC Honor Graduate. At unit discretion, the recipient may be awarded the **Superior Performance ribbon**.

**3. Distinguished Graduates:** The top 10% of cadets will be recognized as either CLC or CSLC Distinguished Graduates based on their overall score (i.e., room inspections, uniform inspections, test scores, PFA score, CTO score). At unit discretion, these cadets are authorized wear a silver star on their CLC ribbon denoting this award.

**4. Drill Competition Winner:** The flight members winning the CLC/CSLC drill competition may be awarded the **Special Teams Placement ribbon**, at unit discretion.

**5. CLC Ribbon:** Is awarded for completion of an approved leadership school program of at least 5 days in duration. For each additional CLC completion an additional bronze star will be awarded.

**6. Major General “Al” Joersz Award:** This award is presented to the top male CLC & CSLC cadets with the highest physical fitness test scores.

**7. Colonel Eileen Collins Award:** This award is presented to the top female CLC & CSLC cadets with the highest PFA scores.

**8. Colonel “Gordo” Cooper Award:** This award is presented to the top CLC & CSLC cadets with the highest academic scores.

## **Appendix 1 – Air Force Chain of Command**

Secretary of the Air Force  
The Honorable Frank Kendall III

Chairman, Joint Chiefs of Staff  
General Mark Milley

Air Force Chief of Staff  
General Charles Brown Jr.

Chief Master Sergeant of the Air Force  
David A. Flosi

Commander, Air Education and Training Command  
Lieutenant General Brian Robinson

Commander, Air University  
Lieutenant General Andrea Tullos

Commander, Holm Center  
Brigadier General Houston Cantwell

Director, Air Force Junior ROTC  
Colonel Johnny McGonigal

## Appendix 2 – CLC/CSLC Chain of Command and Organizational Chart

Commandant  
Lt Col Jody Addison

Superintendent  
MSgt Bryan King

CTO Wing Commander  
2d Lt Gonzalez

CTO Vice Wing Commander  
C/Col Burkman

CTO Training Group Commander  
C/Lt Col Robertson

CTO Squadron 1 Commander  
C/Maj

CTO Squadron 2 Commander  
C/Maj

CTO Squadron 3 Commander  
C/Maj

CTO Squadron 4 Commander  
C/Maj

CTOs A/B/C Flights  
C/Cpts ///

CTOs D/E/F Flights  
C/Cpts ///

CTOs G/H/I Flights  
C/Cpts ///

CTOs J/K/L Flights  
C/Cpts ///

CSLC Cadet Group Commander  
C/Col \_\_\_\_\_

CSLC Cadet Squadron Commander  
C/Lt Col \_\_\_\_\_

Your Flight Commander  
C/Maj \_\_\_\_\_

You  
Cadet \_\_\_\_\_



# 2024 North Texas CLC Organization Chart

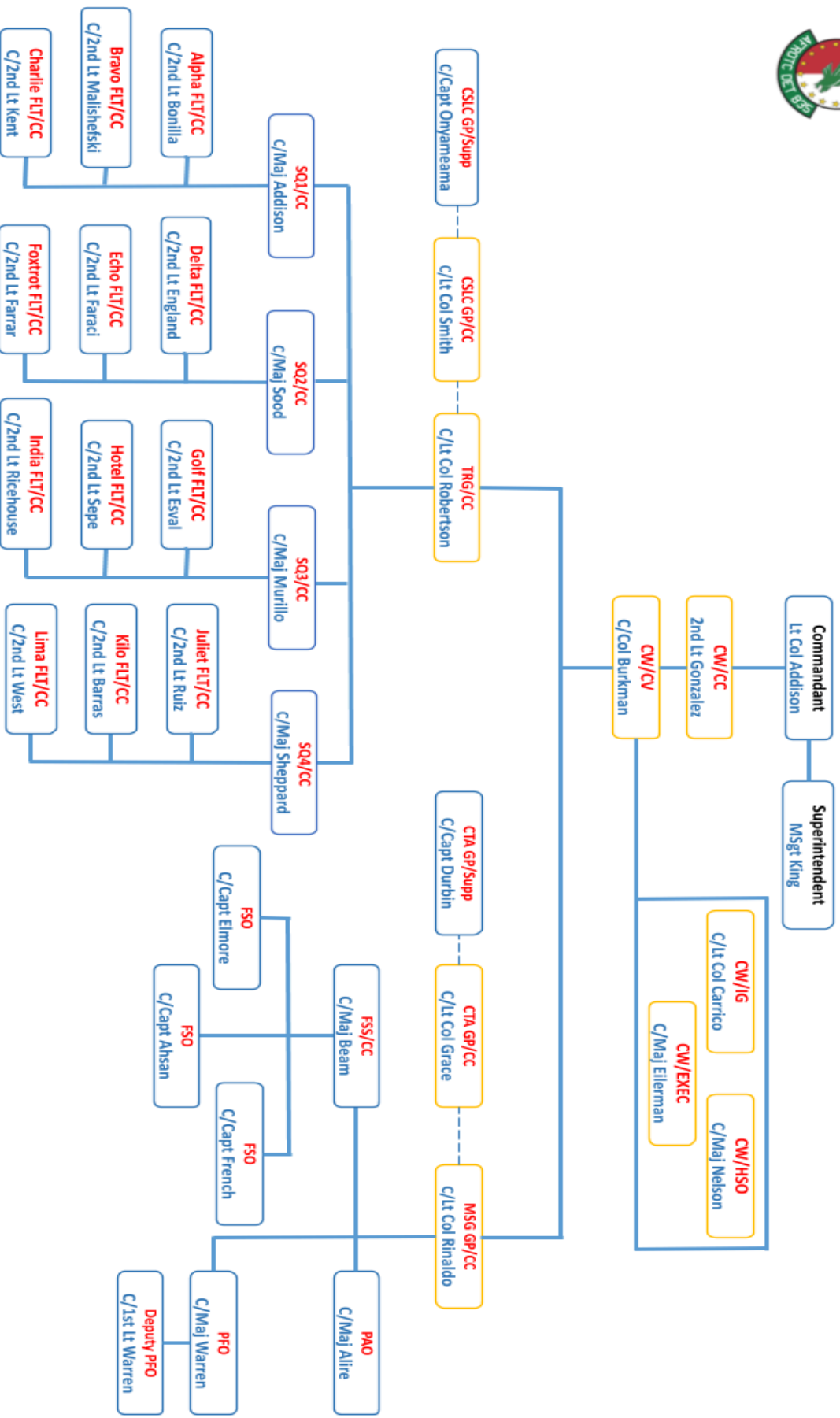



## Appendix 3 – Air Force Rank Structure

### Rank, Pay Grade, and Insignia

#### Enlisted

E-1	E-2	E-3	E-4	E-5	E-6	E-7	E-8	E-8	E-9	E-9			
Air Force													
no insignia													
Airman Basic (AB)	Airman (Amn)	Airman First Class (A1C)	Senior Airman (SrA)	Staff Sergeant (SSgt)	Technical Sergeant (TSgt)	Master Sergeant (MSGt)	First Sergeant (E-7)	Senior Master Sergeant (SMSgt)	First Sergeant (E-8)	Chief Master Sergeant (CMSgt)	First Sergeant (E-9)	Command Chief Master Sergeant (CCM Sgt)	Chief Master Sergeant of the Air Force (CMSAF)

#### Officer

O-1	O-2	O-3	O-4	O-5	O-6	O-7	O-8	O-9	O-10	
Air Force										
										
2nd Lieutenant (2nd Lt.)	1st Lieutenant (1st Lt.)	Captain (Capt.)	Major (Maj.)	Lieutenant Colonel (Lt. Col.)	Colonel (Col.)	Brigadier General (Brig. Gen.)	Major General (Maj. Gen.)	Lieutenant General (Lt. Gen.)	General (Gen.)	General of the Air Force (reserved for wartime only)

# AIR FORCE JUNIOR ROTC INSIGNIA

## CADET OFFICER RANK



SECOND  
LIEUTENANT



FIRST  
LIEUTENANT



CAPTAIN



MAJOR



LIEUTENANT  
COLONEL



COLONEL

## CADET AIRMAN RANK

(no rank insignia)

AIRMAN BASIC



AIRMAN



AIRMAN  
FIRST CLASS



SENIOR  
AIRMAN



STAFF  
SERGEANT



TECHNICAL  
SERGEANT



MASTER  
SERGEANT















SENIOR  
MASTER  
SERGEANT









CHIEF  
MASTER  
SERGEANT

## Appendix 5 – Air Force and Army ROTC Rank Structure

### Air Force ROTC Cadet Officers

Epaulet Rank Boards/Marks	Utility Uniform Rank Pins	Rank (Abbreviation)
		Cadet Colonel (C/Col)
		Cadet Lieutenant Colonel (C/Lt Col)
		Cadet Major (C/Maj)
		Cadet Captain (C/Capt)
		Cadet First Lieutenant (C/1Lt)
		Cadet Second Lieutenant (C/2Lt)

### Army ROTC Cadet Officers

					
CADET 2LT	CADET 1LT	CADET CPT	CADET MAJ	CADET LTC	CADET COL

**Note:** The information on this page is included for your benefit in being able to identify the rank of your CTOs in relationship to the position they hold within the group structure.

## Appendix 6 – Phonetic Alphabet

A – ALPHA  
B – BRAVO  
C – CHARLIE  
D – DELTA  
E – ECHO  
F – FOXTROT  
G – GOLF  
H – HOTEL  
I – INDIA  
J – JULIET  
K – KILO  
L – LIMA  
M – MIKE  
N – NOVEMBER  
O – OSCAR  
P – PAPA  
Q – QUEBEC  
R – ROMEO  
S – SIERRA  
T – TANGO  
U – UNIFORM  
V – VICTOR  
W – WHISKEY  
X – X-RAY  
Y – YANKEE  
Z – ZULU

## Appendix 7 – The Air Force Song, by Robert Crawford (Not ReBranded Version)

Off we go into the wild blue yonder,  
Climbing high into the sun;  
Here they come zooming to meet our thunder,  
At 'em boys (**NOW**), Give 'er the gun! (Give 'er the gun now!)  
Down we dive, spouting our flame from under,  
Off with one helluva roar!  
We live in fame or go down in flame. Hey!  
Nothing'll stop the U.S. Air Force!

Additional verses:

Minds of men fashioned a crate of thunder,  
Sent it high into the blue;  
Hands of men blasted the world asunder;  
How they lived God only knew! (God only knew then!)  
Souls of men dreaming of skies to conquer  
Gave us wings, ever to soar!  
With scouts before And bombers galore. Hey!  
Nothing'll stop the U.S. Air Force!

Bridge: "A Toast to the Host"

Here's a toast to the host  
Of those who love the vastness of the sky,  
To a friend we send a message of his brother men who fly.  
We drink to those who gave their all of old,  
Then down we roar to score the rainbow's pot of gold.  
A toast to the host of men we boast, the U.S. Air Force!

Zoom!

Off we go into the wild sky yonder,  
Keep the wings level and true;  
If you'd live to be a grey-haired wonder  
Keep the nose out of the blue! (Out of the blue, boy!)  
Flying men, guarding the nation's border,  
We'll be there, followed by more!  
In echelon we carry on. Hey!  
Nothing'll stop the U.S. Air Force!

*Notes: Crawford didn't write "Hey!"; he actually wrote "SHOUT!" without specifying the word to be shouted. Wherever they appear, the words "U.S. Air Force" have been changed from the original "Army Air Corps." Words in parentheses are spoken, not sung.*

## Appendix 8 – United States Air Force Core Values

a. ***Integrity First:*** Integrity is essential. It's the inner voice, the source of self-control, the basis for the trust that is imperative in today's military. It's doing the right thing even when no one is looking.

b. ***Service Before Self:*** Military service is not just another job. It's an uncommon profession that calls for people of uncommon dedication. A leader unwilling to sacrifice individual goals for the good of the unit cannot convince other unit members to do so.

c. ***Excellence In All We Do:*** The Air Force mission often involves the risk of human life and sometimes, national survival. The obligation to excel is a moral obligation for members of a professional military service.

## Appendix 9 - Cadet Uniform Requirements

The items listed below are minimum requirements and extra shirts and trousers/slacks would be useful. Ensure your uniforms fit properly and your hair is within standards prior to arrival. Washers/dryers are available, but in limited numbers. Cadets will be washing their PT gear with the rest of their flight, so their items must be labeled in some way or laundered in a single laundry bag to be returned to the wearer. There is no way we can provide extra uniform items to any cadet while at CLC/CSLC, so make sure you come with everything you will need. **Do not bring ropes, medals, wheel hats or high-heeled shoes.**

Cadets that normally wear daily contact lenses are encouraged to wear their glasses during CLC/CSLC due to the limited morning prep time available.

<b>MINIMUM CLOTHING ITEMS CHECKLIST– THESE ARE MINIMUMS, CADETS MAY BRING EXTRA IF DESIRED</b>	
FEMALE	MALE
1 flight cap (with cadet 2d Lt rank, if req'd)	1 flight cap (with cadet 2d Lt rank, if req'd)
1 short sleeve blue shirts w/patch(es)	1 short sleeve blue shirts w/patch(es)
1 pair of blue uniform slacks	1 pair of blue uniform trousers
1 pair of black Oxford shoes (issued)	1 pair of black Oxford shoes (issued)
1 blue AF nametag	1 blue AF nametag
2 white V-neck/tank style t-shirts	2 white V-neck/tank style t-shirts
Athletic (any length) & black (long) socks (for week, if possible)	Athletic (any length) & black (long) socks (for week, if possible)
3 PT shirts & sports bras (as req'd)	3 PT shirts
3 PT shorts	3 PT shorts
Undergarments (for week, if possible)	Undergarments (for week, if possible)
Ribbons	Ribbons
1 pair of cadet SSgt rank for CLC or 1 pair of cadet 2d Lt rank for CSLC	1 pair of cadet SSgt rank for CLC or 1 pair of cadet 2d Lt rank for CSLC
1 belt with buckle	1 belt with buckle
Lightweight blue jacket (optional)	Lightweight blue jacket (optional)
Personal female items	Razor and shaving cream/electric razor
<b>MISCELLANEOUS ITEMS ALL CADETS – THESE ARE MINIMUMS, CADETS MAY BRING EXTRA IF DESIRED</b>	
Travel clothes	
Additional sleepwear (cadets will sleep in PT gear shirt and shorts as minimum)	
Athletic shoes	
Water bottle or hydration pack for personal use throughout week. Required to have with you everywhere except in dorms, so plan accordingly.	
Shower shoes/clogs (required for use and inspection)	
Liquid soap or bar soap with container if not using liquid soap (travel style with a cover)	
Shampoo	
Toothbrush and toothpaste	
Deodorant	
2 towels, 2 washcloths, and a bathmat (optional)...towels may be used for PT and showers. Extra washcloths are encouraged for cleaning the dorm room. Extra cleaning supplies will not be provided.	
Hangars (enough for uniforms, towels and washcloths)	
Standard size pillow with plain (solid color preferred) pillowcase	

Twin-size sheet set w/ blanket. May be extra-long and/or fitted sheet. Sleeping bag is optional if choose to not bring sheets and/or blanket. <b>NOTE – rooms may be cold overnight, bring a blanket or sleeping bag at a minimum.</b>
Other personal toiletries as needed (no perfumes or colognes...aftershave is allowed)
Comb or hairbrush, as required
Hair ties (enough for all week)
Lint brush
Laundry bag or extra pillowcase for dirty laundry
Shoeshine kit (brush and paste only...NO liquid shine, pledge, etc.) with an extra towel to shine shoes on to catch any dropped/smeared polish.
Moleskin or blister care pack and/or bandages
Sharpie for laundry marking
Fingernail clippers
Sunscreen and insect repellent. Many afternoon outdoor activities and evening sports in fields.
12" ruler
Small flashlight for overnight bathroom use
Pens/pencils/spiral notebook...something to write with and on is <b>MANDATORY</b>



## Appendix 10 – CLC Cadet Uniform Inspection Checklist

<b>CLC/CSLC Open Ranks Uniform Inspection Scoresheet</b>			
<b>Cadet Name:</b>			
<b>Flight:</b>			
Inspectors will note gigs for each infraction not in AFJROTC standards			
<b>Inspection Item</b>	<b>Wed</b>	<b>Fri</b>	<b>Notes</b>
Cover (worn correctly)			
Hair			
Shave			
Rank (alignment)			
Blue shirt (clean/pressed)			
Buttons buttoned			
V-neck t-shirt			
Patch(es)			
Name tag (alignment)			
Ribbons (alignment/order)			
Badges (alignment)			
Pants (clean/pressed)			
Gig line			
Belt			
Buckle			
Make-up (appropriate)			
Nail polish (appropriate)			
Strings/lint			
Shoes (shined)			
Socks (black/calf)			
Bearing			
<b>Total Gigs</b>			
<b>Score (100 – (Gigs x 2))</b>			
<b>Inspector Initials</b>			

## 10.1 Open Ranks Inspection Procedures

### OPEN RANKS

The command is “**Open Ranks, MARCH.**” It is only given to a formation when in line at normal interval. The flight commander proceeds and aligns the flight. Once the flight is aligned, the flight commander commands “**Ready, FRONT.**” The flight commander takes one step forward and faces to the right in a position in front of the guide (or first element leader if there is no guide).

The flight commander salutes and reports to the inspector “**Sir (Ma’am), \_\_\_\_\_ Flight is prepared for inspection.**” As soon as the flight commander has been inspected, he or she is asked to accompany the inspector. The flight commander then executes a left face (down line) and commands “**Second, Third, and Fourth Elements, Parade, REST.**” The flight commander executes a half left in marching without arm swing and halts one pace to the right and one pace to the rear of the inspector (this causes the flight commander to precede the inspector). This position is maintained throughout the inspection of the front of each respective rank. When moving from individual to individual during the inspection, the inspector and flight commander simultaneously execute a face to the right in marching and an in-place halt.

### CLOSE RANKS

After inspecting the entire flight, the inspector marches off to the right flank (element leaders) of the flight. The flight commander proceeds directly to a position three paces beyond the front rank, halts, faces to the left (down line), and commands “**Flight, ATTENTION**” The flight commander then takes one step forward with arm swing and faces to the right. The inspector marches to a position directly in front of the flight commander and gives comments. After receiving comments, the flight commander salutes. The flight commander then faces left (down line) and commands “**Close Ranks, MARCH.**” He or she then gives “**Parade REST,**” “**AT EASE,**” or “**REST**” (whichever is appropriate) and posts in front of and centered on the flight. The flight commander commands “**Flight, ATTENTION**” and “**FALL OUT.**”

### Knowledge

Basic Knowledge will consist of questions related to general Air Force information. This may include Air Force chain of command (from the President through the AFJROTC Director), drill and ceremonies, dress and appearance, rank and structure, history, and organization.

During uniform inspections, instructors/CTOs will ask questions to determine a cadet's poise, confidence, and knowledge of the subject in the previous paragraph. They will also ask questions they do not expect the cadet to answer correctly. Cadets must not become flustered or lose their military bearing! If a cadet does not know the answer to any question, a strong, “Sir/Ma’am, this cadet does not know,” or similar response, is best.

## Appendix 11 – CLC Cadet Room Inspection Checklist/Scoresheet

<b>Cadet Name:</b>	<b>Flight:</b>
<b>Room:</b>	

Inspection Item	Wed Insp Initials:	Thurs Insp Initials:	Fri Insp Initials:
<b>General Room Cleanliness</b>			
Window/Blinds			
Dresser			
Desk/Chair			
Floor			
Doors			
<b>Bed</b>			
Alignment			
Pillow			
Blanket			
Sheets			
<b>Top Drawer</b>			
2" Opening			
Shirts			
Shorts			
Underwear & bras			
Black socks			
Athletic socks			
<b>Middle Drawer</b>			
2" Opening			
Toothpaste			
Deodorant			
Soap/Shampoo			
<b>Bottom Drawer</b>			
2" Opening			
Items neat and grounded			
<b>Closet</b>			
Uniform shirt			
Uniform pants			
Towel			
Washcloth			
Shoes			
Luggage/Garment bags			
<b>Bathroom</b>			
Shower curtain			
Sink			
Mirror			
Toilet			
<b>Total Gigs</b>			
<b>Score (100 – (Gigs x 2))</b>			

## Appendix 12 – Formal Drill Competition

### Formal Drill Competition

Cadets must know how to drill and know drill terminology. Flights will perform the 30-Step drill sequence for competition.

Flights may nominate or have their 30-Step drill Flt/CC volunteer for the drill competition.

### Definitions

The following are the most common terms referred to when teaching, demonstrating, and executing drill.

**Alignment:** dress or cover.

**Base:** the element on which a movement is planned, regulated, or aligned.

**Cadence:** the uniform step and rhythm in marching; that is, the number of steps marched per minute.

**Center:** the middle point of a formation. On an odd-numbered front, the center is the center person or element. On an even-numbered front, the center is the right (as viewed from within the formation) center person or element.

**Cover:** individuals aligning themselves directly behind the person to their immediate front while maintaining proper distance.

**Depth:** the total space from front to rear of any formation. An individual's depth is considered to be 12 inches.

**Distance:** the space from front to rear between units. The distance between individuals in formation is 40 inches as measured from their chest to the backs of individuals directly in front of them. Flight commanders, guides, and others whose positions in formation are 40 inches from a rank are themselves considered a rank.

**Double Time:** the rate of marching at 180 steps (30 inches in length) per minute

**Dress:** alignment of elements side by side or in line maintaining proper interval.

**Element:** the basic formation; that is, the smallest drill unit comprised of at least 3, but usually 8 to 12 individuals, one of whom is designated the element leader.

**File:** a single column of persons placed one behind the other.

**Final Line:** the line on which the adjutant forms the front ranks of troops for a parade or review.

**Flank:** the extreme right or left (troops' right or left) side of a formation in line or in column.

**Flight:** at least two, but not more than four, elements.

**Formation:** an arrangement of units.

**Front:** the space occupied by a unit, measured from flank to flank. The front of an individual is considered to be 22 inches.

**Guide:** the airman designated to regulate the direction and rate of march.

**Head:** the leading unit of a column.

**In Column:** the arrangement of units side by side with guide and element leaders to the head.

**In Line:** the arrangement of units one behind the other with the guide and element leader to the extreme right flank.

**Interval:** the space between individuals placed side by side. A normal interval is an arm's length. A close interval is 4 inches.

**Inverted Column:** the arrangement of units side by side with guide and element leaders to the rear.

**Inverted Line:** the arrangement of units one behind the other with the guide and element leaders to the extreme left flank.

**Line of March:** a line followed by troops as they pass in review.

**Mark Time:** marching in place at a rate of 100 to 120 steps per minute.

**Mass Formation:** the formation of a squadron or group in which the component units are in column, abreast of each other, and at close interval.

**Pace:** a step of 24 inches. This is the length of a full step in quick time.

**Post:** the correct place for an officer, noncommissioned officer (NCO), or airman to stand while in formation.

**Quick Time:** the rate of marching at 100 to 120 steps (12 or 24 inches in length) per minute.

**Rank:** a single line of persons placed side by side.

**Ready Line:** a forming line 20 paces to the rear of the final where the troops are formed for a parade or review at an established time prior to adjutant's call.

**Reviewing Officer:** the senior officer participating in a parade or review.

**Slow Time:** the rate of marching at 60 steps per minute (used in funeral ceremonies)

**Step:** the distance measured from heel to heel between the feet of an individual marching.

**Unit:** any portion of a given formation.

## Types of Commands

A drill command is a verbal order. Most drill commands have two parts, the preparatory command and the command of execution. The preparatory command explains what the movement will be. When calling a unit to attention or halting a unit's march, the preparatory command includes the unit's designation. In the command "Flight, **HALT**," the word "Flight" is the preparatory command. At the same time, it designates the unit being addressed.

The command of execution follows the preparatory command. The command of execution explains when the movement will be carried out. In "Forward, **MARCH**," the command of execution is "**MARCH**."

In certain commands, the preparatory command and the command of execution are combined, for example: "**FALL IN**," "**AT EASE**," and "**REST**." The commands are given at a uniformly high pitch and a louder volume than a normal command of execution.

Supplemental commands are given when one unit of the element must execute a movement different from the other units or must execute the same movement at a different time. Two examples are "**CONTINUE THE MARCH**" and "**STAND FAST**."

Informational commands have no preparatory command or command of execution and they are not supplementary. Two examples are "**PREPARE FOR INSPECTION**" and "**DISMISS THE SQUADRON**."

## Flight Commanders

Prior to marching a flight, the commander must follow proper guidelines to ensure the flight is sized appropriately and are prepared to conduct drill and ceremonies. The following procedures should be accomplished in normal drill and ceremony situations; however, they may be modified for drill competition or evaluations.

The first command is “**FALL IN.**”

On this command, the guide takes a position facing the flight sergeant and to the flight sergeant’s left so the first element will fall in centered on and three paces from the flight sergeant. Once halted at the position of attention, the guide performs an automatic dress right dress. When the guide feels the presence of the first element leader on his or her fingertips, the guide executes an automatic ready front. Once positioned, the guide does not move.

The first element leader falls in directly to the left of the guide and, once halted, executes an automatic dress right dress. The second, third, and fourth element leaders fall in behind the first element leader, execute an automatic dress right dress, visually establish a 40-inch distance, and align themselves directly behind the individual in front of them. The remaining airmen fall into any open position to the left of the element leaders and execute an automatic “dress right, dress” to establish dress and cover.

To establish interval, the leading individual in each file obtains exact shoulder-to-fingertip contact with the individual to his or her immediate right. As soon as dress, cover, interval, and distance are established, each airman executes an automatic ready front on an individual basis and remains at the position of attention.

Once it is formed, the flight will be squared off prior to sizing. The left flank of the formation will be squared off with extra airmen filling in from the fourth to the first element. For example, if there is one extra airman, he or she will be positioned in the fourth element; if there are two extra airmen, one will be positioned in the third element and one will be positioned in the fourth element; and so forth.

To size the flight, the flight commander faces the flight to the right (from line to column formation) and has taller personnel (except the guide, element leaders, and flight sergeant) move to the front of the flight according to height. The flight commander then faces the flight to the right (from column to inverted line formation) and again has taller personnel (except the flight sergeant) move to the front of the flight according to height. The flight commander faces the flight back to the left (column formation) and continues this procedure until all members are properly sized.

Each member of the flight has a number except the guide. Numbering of individual members of a flight is from right to left (when in line formation) and from front to rear (when in column formation). The element leader is always number one.

The 30-step Flight Drill Evaluation Sheet is on the next page. All CLC/CSLC cadets must be able to execute all movements with snap and precision. A score of 0 means failure to execute the maneuver or unsatisfactory execution, 5 represents satisfactory execution (some mistakes), and

10 represents outstanding execution (no mistakes of any kind). The flight will also be graded on their military bearing as well as sharpness during execution.

The Flt/CC will be graded on proper command voice, their command presence (reflected in the sharpness or “snap” in the flight), and military bearing. The commander is responsible for ensuring proper completion of the sequence. In the event a flight ties another flight, the Flt/CC’s score and notes will be used to break the tie.

A full explanation of the 30-step drill sequence to include proper commands and when to call the commands follows the Flight Drill Evaluation Sheet. Study this closely to ensure you execute the drill sequence correctly and up to AFJROTC standards.

### 30-BASIC MARCHING EVALUATION

Commander: \_\_\_\_\_

School/Flight: \_\_\_\_\_

**Section 1 Judge**

SEQUENCE ITEM	Score
Flight FALL IN	0 1 2 3 4 5 6 7 8 9 10
Open Ranks MARCH	0 1 2 3 4 5 6 7 8 9 10
Ready FRONT	0 1 2 3 4 5 6 7 8 9 10
Close Ranks MARCH	0 1 2 3 4 5 6 7 8 9 10
Present ARMS	0 1 2 3 4 5 6 7 8 9 10
Order ARMS	0 1 2 3 4 5 6 7 8 9 10
Parade REST	0 1 2 3 4 5 6 7 8 9 10
Flight ATTENTION	0 1 2 3 4 5 6 7 8 9 10
Left FACE	0 1 2 3 4 5 6 7 8 9 10
About FACE	0 1 2 3 4 5 6 7 8 9 10
Forward MARCH	0 1 2 3 4 5 6 7 8 9 10
Right Flank MARCH	0 1 2 3 4 5 6 7 8 9 10
Left Flank MARCH	0 1 2 3 4 5 6 7 8 9 10
Column Right MARCH	0 1 2 3 4 5 6 7 8 9 10
Forward MARCH	0 1 2 3 4 5 6 7 8 9 10
To The Rear MARCH	0 1 2 3 4 5 6 7 8 9 10
To The Rear MARCH	0 1 2 3 4 5 6 7 8 9 10
Column Right MARCH	0 1 2 3 4 5 6 7 8 9 10
Forward MARCH	0 1 2 3 4 5 6 7 8 9 10
Eyes RIGHT	0 1 2 3 4 5 6 7 8 9 10
Ready FRONT	0 1 2 3 4 5 6 7 8 9 10
Column Right MARCH	0 1 2 3 4 5 6 7 8 9 10
Forward MARCH	0 1 2 3 4 5 6 7 8 9 10
Change Step MARCH	0 1 2 3 4 5 6 7 8 9 10
Column Right MARCH	0 1 2 3 4 5 6 7 8 9 10
Forward MARCH	0 1 2 3 4 5 6 7 8 9 10
Flight HALT	0 1 2 3 4 5 6 7 8 9 10
Left FACE	0 1 2 3 4 5 6 7 8 9 10
Right Step MARCH	0 1 2 3 4 5 6 7 8 9 10
Flight HALT	0 1 2 3 4 5 6 7 8 9 10
Fall Out	0 1 2 3 4 5 6 7 8 9 10
<b>Sub Total</b>	<b>/310</b>

**Section 2 Judge**

Commander's Score	Score
Voice	0 1 2 3 4 5 6 7 8 9 10
Position	0 1 2 3 4 5 6 7 8 9 10
Bearing	0 1 2 3 4 5 6 7 8 9 10
Presence	0 1 2 3 4 5 6 7 8 9 10
Control of Flight	0 1 2 3 4 5 6 7 8 9 10
<b>Total</b>	<b>/50</b>
Flight Discipline	Score
Bearing	0 1 2 3 4 5 6 7 8 9 10
Execution	0 1 2 3 4 5 6 7 8 9 10
Precision	0 1 2 3 4 5 6 7 8 9 10
Dress/Cover	0 1 2 3 4 5 6 7 8 9 10
<b>Total</b>	<b>/40</b>
<b>Drill Score</b>	<b>Add Sequence + Flight</b>
<b>Total</b>	<b>/350</b>
<b>Final Score</b>	<b>Drill Score + Commander</b>
<b>Total</b>	<b>/400</b>



## Appendix 13 – 30-Step Drill Sequence Explained

### **30-step Drill Sequence**

#### **“FALL IN”**

A flight forms in at least two, but not more than four, elements in line formation. On the command, the guide takes a position facing the flight commander and to the left so the first element will fall in centered on, and three paces from, the flight commander. Once halted at the position of attention, the guide performs an automatic “dress right, dress.” When the guide feels the presence of the first element leader on their fingertips, the guide executes an automatic “ready, front.” The first element leader falls in directly to the left of the guide and executes an automatic dress right dress. The second, third, and fourth element leaders fall in behind the first element leader, execute an automatic dress right dress, visually establish a 40-inch distance, and align themselves directly behind the individual in front of them. The remaining airmen fall into any open position to the left of the element leaders and execute an automatic dress right dress to establish dress and cover.

#### **“Open Ranks, MARCH”**

Only given to a formation when in line at normal interval. Once halted, the distance between ranks will be 70 inches.

#### **“Ready, FRONT”**

The flight commander marches three paces beyond the front rank, halts, and faces to the left (down line).

#### **“Close Ranks, MARCH”**

#### **“Present, ARMS”**

#### **“Order, ARMS”**

#### **“Parade REST”**

#### **“Flight, ATTENTION”**

#### **“Left, FACE”**

#### **“About, FACE”**

Individuals align themselves directly behind the person to their immediate front while maintaining proper distance. Command can be executed anytime the flight is halted.

#### **“Forward, MARCH”**

#### **“Right Flank, MARCH”**

#### **“Left Flank, MARCH”**

#### **“Column Right, MARCH”**

#### **“Forward, MARCH”**

#### **“To the Rear, MARCH”**

#### **“To the Rear, MARCH”**

#### **“Column Right, MARCH”**

“Forward, **MARCH**”

“Eyes, **RIGHT**”

The preparatory command and the command of execution are given on the right foot while marching. On the command **RIGHT** all persons, except those on the right flank, turn their heads and eyes smartly 45 degrees to the right.

“Ready, **FRONT**”

The command is given as the left foot strikes the ground. On the command **FRONT**, heads and eyes are turned smartly to the front.

“Column Right, **MARCH**”

“Forward, **MARCH**”

“Change Step, **MARCH**”

On the command **MARCH**, given as the right foot strikes the ground, the cadet takes one more 24-inch step with the left foot. Then in one count, place the ball of the right foot alongside the heel of the left foot, suspend arm swing and shift the weight of the body to the right foot. Step off with the left foot in a 24-inch step, resuming coordinated arm swing. The upper portion of the body remains at the position of attention throughout.

“Column Right, **MARCH**”

“Forward, **MARCH**”

“Flight, **HALT**”

“Left, **FACE**”

“Right Step, **MARCH**”

Command is given only from the halt and for moving short distances. On the command, March, the cadet raises the right leg from the hip just high enough to clear the ground. The leg will be kept straight, but not stiff, throughout the movement. The individual places the right foot 12 inches, as measured from the inside of the heels, to the right of the left foot. Transfer the weight of the body to the right foot, then bring the left foot (without scraping the ground) smartly to a position alongside the right foot. The upper portion of the body remains at attention and arms remain at the sides throughout. Cadence may be counted. Counts 1 and 3 are given as the right foot strikes the ground. Counts 2 and 4 are given as the heels come together.

“Flight, **HALT**”

To halt, the preparatory command and command of execution are given as the heels come together. On the command, “**HALT**,” one more step is taken with the right foot and the left foot is placed smartly alongside the right foot as in the position of attention.



2024



# AIR FORCE JUNIOR ROTC



# NORTH TEXAS CADET LEADERSHIP COURSE & SENIOR LEADERSHIP COURSE GUIDE